



INTEGRITY METALS

Architectural Fabrication

EXPOSED FASTENER INSTALLATION MANUAL

INTEGRITYMETALSFL.COM



TABLE OF CONTENTS

SAFETY	3
HANDLING	3
STORAGE	3
RECOMMENDED TOOLS AND EQUIPMENT	4
FIELD CUTTING PANELS	4
PREPARING TO INSTALL YOUR NEW ROOFING.....	5
New Construction	5
Re-Roofing Existing Structures.....	6
Panel Installation	7
Fastener Installation	8
ROOF MAINTENANCE	9
Personal Safety	9
Annual Maintenance Actions.....	9
TRIM DETAILS.....	11

Effective Date: May 6, 2022

CONGRATULATIONS ON YOUR METAL ROOF PACKAGE FROM INTEGRITY METALS!

A properly installed and well-maintained metal roof can last 40+ years and is a great investment. Be sure to follow these guidelines to ensure the best performance from your metal roofing system.

SAFETY

Safety is always your first consideration when installing your metal roofing package. Hazards exist on the ground as well as on the roof.

- Always be aware where you are on the roof. Openings, edges, electrical lines and tripping hazards (cords and equipment) are constant danger.
- Watch electrical lines when maneuvering panels.
- Never install metal roofing on windy or stormy days. The wind can get under the panel and force you off the roof. Once the panel is loose and airborne it can become a sharp projectile.
- Roofing can be very slick when dusty, wet, or covered with frost. Avoid being on the roof when these conditions are present.
- Never step on panels until they are in place and secured with fasteners. Then only step in flat areas and never on the panel ribs.
- Wearing soft soled shoes will help with traction while preventing scratching the panels.
- Use fall protection where needed or required by OSHA or other standards.
- Be aware of your coworker. Make sure they are not putting themselves in danger.
- If your building has an open purlin system be sure to walk along the purlins and not in between as this may result in injury.

HANDLING

To avoid damage, handle your panels and trim with care. Longer panels may need more than one lift point; always keep the full length supported to avoid damage from bending or twisting.

STORAGE

Integrity Metals recommends that you have your structure built before ordering your metal. With FINAL building measurements, your materials can then be ordered based on the actual as-built dimensions of the structure. Because of our quick turnaround time, you will

typically have the material in a matter of one to three days. The longer the metal roof package is stored at your work site, the more opportunity for damage to occur. If you cannot install the metal right away, proper storage is a must. Store metal panels and other materials in a covered, dry, well ventilated area ensuring moisture and direct sunlight are kept away from panels.

If stored outside, wrap a tarp loosely around the panel bundles so air can circulate freely to avoid moisture build-up. One end of the bundle must be elevated so any accumulated moisture can run off. Do not allow water to pond on the panels, and never store materials in direct contact with the ground. If the trim package you receive has a protective plastic film on it, the film must be removed within 15 days.

RECOMMENDED TOOLS AND EQUIPMENT

To avoid damage, handle your panels and trim with care. Longer panels may need more than one lift point; always keep the full length supported to avoid damage from bending or twisting.

- Screw gun (use of impact drivers will void the warranty for most screws)
- Drill bits
- Tin snips (right & left)
- Tape measure
- Pop rivet tool
- Chalk line
- Hemming tool
- Locking pliers
- Nibbler

****INTEGRITY METALS DOES NOT ALLOW THE USE OF CIRCULAR SAWS TO CUT METAL PANELS OR TRIM.***

FIELD CUTTING PANELS

Tin snips or nibblers are recommended for cutting metal panels and trim. All cut metal shavings must be removed from the panel to prevent damage to the finish. One way to prevent shavings on the finish side of the panel is to cut from the primer side of the panel. Never cut panels on top of existing panels. Always wear gloves and eye protection when cutting metal panels. All installed products should be wiped free of any debris at the end of each workday.



CAUTION! Clean all metal shavings and particles off of roof to avoid unsightly rust stains.

PREPARING TO INSTALL YOUR NEW ROOFING

Integrity Metals quality metal roofing packages can be used for new or existing structures.

NEW CONSTRUCTION

- 1** If you need openings cut for venting through ridge or plumbing vents or electrical conduits, cut those in before installation.
- 2** Any siding, stucco or painting work should be done prior to any metal work.
- 3** It is very important to check for protruding nails and other objects which may puncture the underlayment and roofing panels. Be sure to clean all foreign materials from the roof.
- 4** Cover the deck with a moisture barrier such as a minimum 30# felt or other approved underlayment. Begin at the eave and roll the underlayment horizontally (along the eave). Overlap the next strip at least 3 inches or as required by local code or as recommended by the underlayment manufacturer. Integrity Metals recommends placing a hi-temp ice & water membrane underlayment over the entire roof area (or at a minimum in areas in which snow, ice, and rain can accumulate, such as valleys and eaves).
- 5** Place an alignment line along the gable end where the first panel will be installed. This line must be parallel to the gable edge of the roof and square with the eave edge. Check the roof for squareness by making a 3-foot line across the eave (see illustration). Completing the 3' x 4' x 5' triangle should place the 4' line parallel along the gable edge. The first panel will be placed along this line. Any out of square conditions up to 3" can be covered by the gable trim.

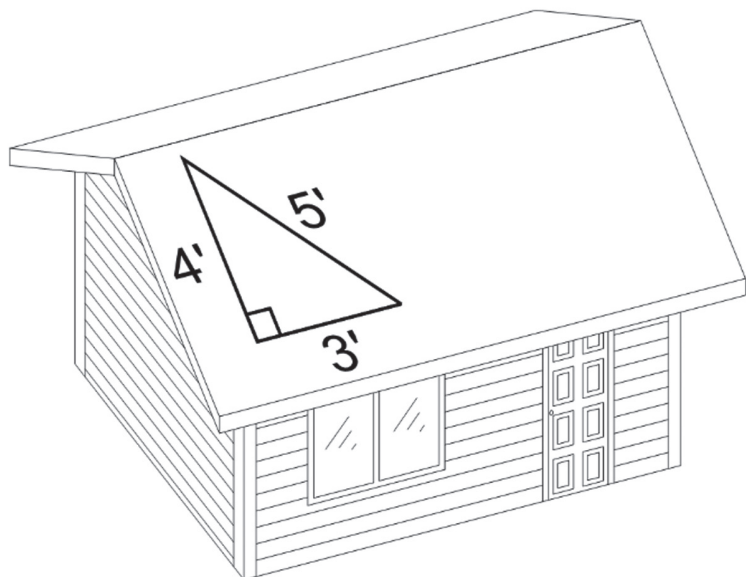

It is important to measure the roof from gable to gable. Proper placement of panels will allow the panel ribs on each side to be covered by the gable trim while creating a symmetrical appearance on the roof.

RE-ROOFING EXISTING STRUCTURES

It's best if existing roofing (e.g. shingles, etc.) is removed so there is a smooth, flat substrate for installing metal roofing panels. Metal roofing should never be installed over an uneven surface.

Another good reason for stripping a roof is to fully examine decking. Reroofing is the perfect time to look for any defects which may need repair or replacement.

Never apply metal roofing over a damaged substrate.

When removing existing roofing and installing over a clean roof deck follow the instructions for new construction as previously described.

To install over existing roofing, inspect the roof for defects and repair so new roofing has a flat surface to be applied to.

- 1** Secure or remove any warped roofing. Ensure the surface is flat, level, and smooth.
- 2** Make sure there are no protruding nails or other objects which may affect the new underlayment or roofing panels.
- 3** Remove all moss and other debris.
- 4** Remove all hip cap, ridge cap, and penetration flashing.
- 5** Cover the deck with a moisture barrier such as a minimum 30 # pound felt or other approved underlayment. Begin at the eave and roll the underlayment horizontally (along the eave). Overlap the next strip at least 3 inches. (Place a hi-temp ice & water membrane underlayment in areas which snow, ice, and rain can accumulate, such as valleys and eaves. This will be applied to the roof before rolling out the 30# felt).
- 6** Place an alignment line along the gable end where the first panel will be installed. This line must be parallel to the gable edge of the roof and square with the eave edge. Check the roof for squareness by making a 3-foot line across the eave (see illustration, Page 5). Completing the 3' x 4' x 5' triangle should place the 4' line parallel along the gable edge. The first panel will be placed along this line. Any out of square conditions up to 3" can be covered by the gable trim.

It is important to measure the roof from gable to gable. Proper placement of panels will allow the panel ribs on each side to be covered by the gable trim while creating a symmetrical appearance on the roof.

PANEL INSTALLATION

Study the trim details in this manual before installing the panels. Pay close attention to Valleys, Eaves, and Transitions.

Follow these basic guidelines:

- 1 Install eave and valley trim prior to panel installation.
- 2 Always install your panels into the prevailing wind (with the lap opening facing away from prevailing wind).
- 3 Align the edge of the first panel with the alignment line constructed along the gable end. Allow the panel to overhang the eave 1 to 2". (If venting through the ridge make sure you hold the underlayment down 2" from the ridge. Also make sure your decking is 2" down from the top of the ridge on both sides. Doing this will allow for air circulation in the attic space.)
- 4 After the first panel is properly aligned, fasten per the fasteners placement and spacing guide located in your Florida Product Approval. Lay down second and third panels, check the alignment, and be sure they are square. You may have to stretch or shrink the panel by either pulling the top or bottom of the panel to make up the distance needed to be square. If you have over a 1/4" to make up it is best to stretch or shrink the panel over the next few panels.
- 5 After the panels are installed, you can install the remaining trim and flashing. Start at the eave edges and work from the bottom upwards. For example, place gable trim starting at the bottom edge and work towards the ridge. If pieces must be overlapped; a 4" minimum is recommended. Once the gable trim is installed, ridge cap may be installed. Please see trim details on how each piece of trim is installed. It is recommended that you trim the roof as you go to avoid any unnecessary foot traffic on the roof panels.

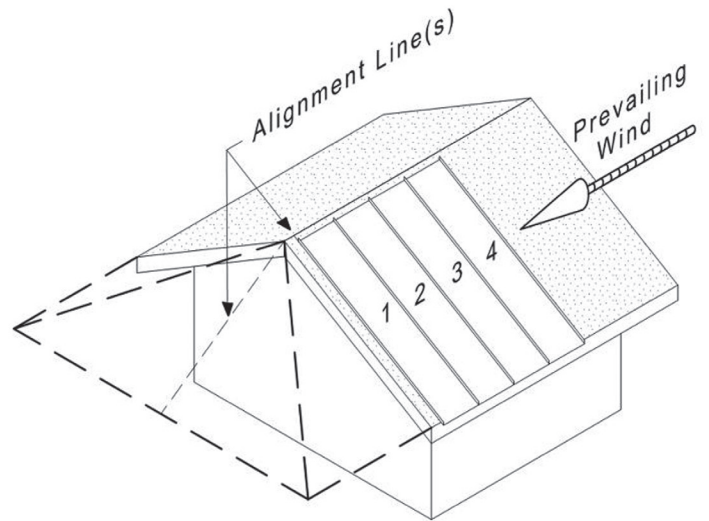

FASTENERS

Correct

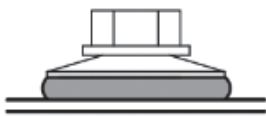

EPDM material is compressed and visible at washer.
Fastener is properly installed.

Too Loose

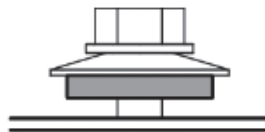

EPDM material not at visible joint.
Not enough compression to make a seal.

Too Tight

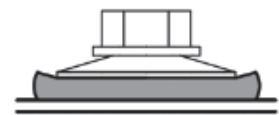

Fastener is over-driven and EPDM material is protruding beyond edge of fastener.

FASTENER INSTALLATION

Screws have been shown to have 2 to 3 times the holding power of nails. For maximum holding power, it is recommended that the minimum wood penetration be 1/4 inch and that the fasteners not be overtightened. Overtightening/over-torquing will strip out the wood substrate and limit the holding power the fastener.

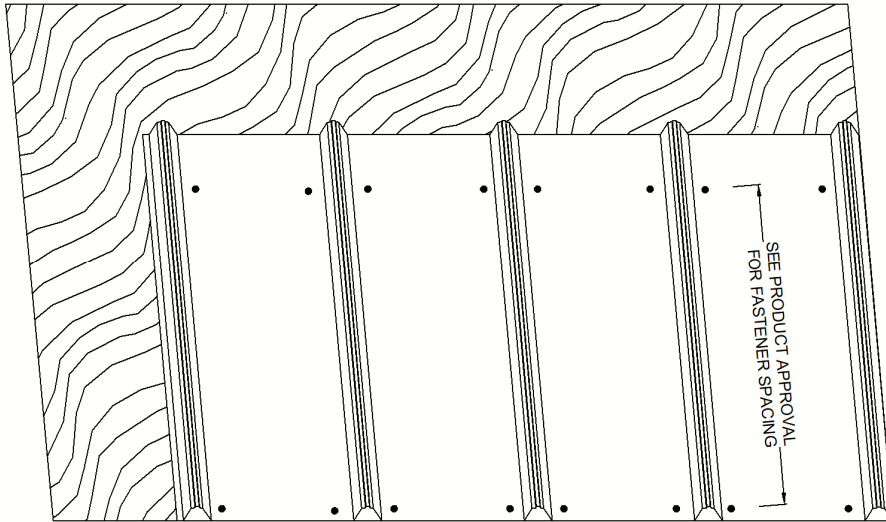

FASTENER PLACEMENT

Always fasten per the fasteners placement and spacing guide located in your Florida Product Approval. The use of a screw gun is recommended as the use of impact drivers will void the warranty for most screws.

IMPORTANT INSTALLATION REMINDERS

To prevent damage to panels and trim, install immediately or store in a cool dry area. Carbonized Steel, Galvanized Steel, Aluminized Steel, Galvalume and all alloys of Aluminum are susceptible to what is commonly referred to as "White" or "Black" rust and water stain, these are caused by electrolysis, which occurs when moisture exists between stacked sheets.

Painted metal products are also susceptible to a change of or loss of paint gloss discoloration, delaminating, disintegrating, and other accelerated defects of the paint as a result of moisture between the panels sheets.

Integrity Metals assumes no responsibility of liability for damage to our product which occurs in the possession of the consignee or which we deem to be the result of improper handling and storage.

If panels are to be cut or drilled, be certain to wipe free any metal filings that may accumulate. Protective plastic film on the trim should be removed within 15 days. Failure to follow these instructions may void the warranty.

ROOF MAINTENANCE

All roofs, metal, tile or shingle, require periodic maintenance. There are certain procedures that an owner can perform in order to maintain the longevity of their roof. Be sure to consult an expert to perform any complex repair or addition. If necessary, Integrity Metals can connect you with a qualified roofing contractor.

PERSONAL SAFETY

Safety is the top priority, climbing ladders and walking on any roof can be dangerous. Always use some method of fall protection that is approved by OSHA. Failure to provide the required safety equipment can result in serious injury or death.

During the roof inspection, remember to take the following precautions:

- Use fall protection and all required safety equipment.
- Keep foot traffic to a minimum. Only walk on the roof if absolutely necessary.
- Never walk on eave or rake flashings, gutters, hip, or ridge flashings.
- Never walk on any skylight or fiberglass type panels.
- Always walk in the flat area of the panel and near the roof panel supports.
- Don't wear black soled shoes; the marks they leave are almost impossible to remove.
- Soft-soled shoes are recommended.

ANNUAL MAINTENANCE ACTIONS

The following are a few of the actions to complete (yourself or professionally). Failure to do so could decrease your roof's life dramatically and in some instances void your warranty:

- All coastal aluminum systems require (2) annual sweetwater baths to maintain the warranty. ("Coastal" systems are those within 1500 ft from salt or brackish water, or as defined in current warranty documents.)
- Clean gutters, down spouts, and drain boxes. Leaves and debris can back up an entire gutter system and the overflowing gutters can cause leaks and damage.
- Inspect for tree branches or other items which are touching the roof. Remove items.
- Look for loose flashings, roof sheets, fasteners, or punctures from falling objects.

- Clear the valleys and waterways of the roof. Leaves and other debris can block the flow of water in valleys or drainage paths. This must be cleaned out regularly, especially if you have trees that overhang your roof. Pooling areas from dirt piles or rotted debris will degrade the roof surface and may even allow plants to grow.
- Check roof penetrations for possible leaks. Leaks most often come from heat or air vents and skylights. Some leaks are caused by the shrinking or hardening of applied silicones as they dry out. If there is a crack or a suspected area, fill it using a Metal Roofing Sealant which is permanently flexible and won't crack.
- Inspect areas around chimneys, heat vents, oil condensers above cooking areas and air conditioners. These areas can expose your roofing to chemicals that will break down the paint system and can corrode the metal.
- Inspect your roof paint for scratches. Should this occur, clean the area with mineral spirits. Rinse completely with water and allow to dry. Using paint supplied from the manufacturer of the panel, apply a minimum amount of paint to cover the scratched area. This may need to be touched up again in several years.
- Integrity Metals does not promote caulk or sealant dependent roof systems. Exposed sealants will break down over time due to UV and other exposure, and are a common source of leaks. Integrity Metals can manufacture any custom part to ensure a proper weathertight roof.
- If exposed fasteners have been used on your roof, it is imperative that they are inspected annually. The inspection entails several key points:
 - A. Are the fasteners installed correctly? (See image on page 7.) Sometimes fasteners are overtightened which may cause them to cut or split the neoprene washers.
 - B. Other fasteners may not be tightened properly which will not create a seal between the fastener and the metal panel or flashing.
 - C. Neoprene washers may break down over time due to expansion and contracting of the metal panels or from exposure to UV rays. By rubbing your fingernail over the washer you will notice if it is still flexible or has hardened and is breaking apart.
- Finally, look at the closures or venting materials under the ridge caps, transitions, end walls and valleys. At times this material can come loose or break down from sun exposure and cause leaks. Replace as necessary. If you find any problems and you cannot repair them yourself, contact your installer or Integrity Metals to see how the problem can be resolved.



TRIM DETAILS

The following pages show Integrity Metals' suggested trim details for general purpose use. Note that specific project or local building codes may have differing requirements. Always consult local building codes and the project documents for your specific project.

ORDERING TRIM

- **Trim Dependent on Roof Slope** - Some trim dimensions are dependent on the slope of the roof. When "Specify Slope" is noted, be sure to include the required roof slope when ordering that trim. Example: "Drip for 4:12 roof."
- **Customized Trim** - Some trims can be customized. These are indicated with a label such as "A: ##" or "B: ##".

To Order Custom Sized Trim:

1. Determine if a specific trim is eligible for custom sizing.
2. Let us know the side/leg (A, B, or C) requiring a custom size with the dimension you need.

Example: For the application at right, the default vertical leg of 4" will not cover the gap from siding. To order the correct size your custom trim order would be:

Side/Leg A: 4 Inches
Side/Leg B: 6 Inches

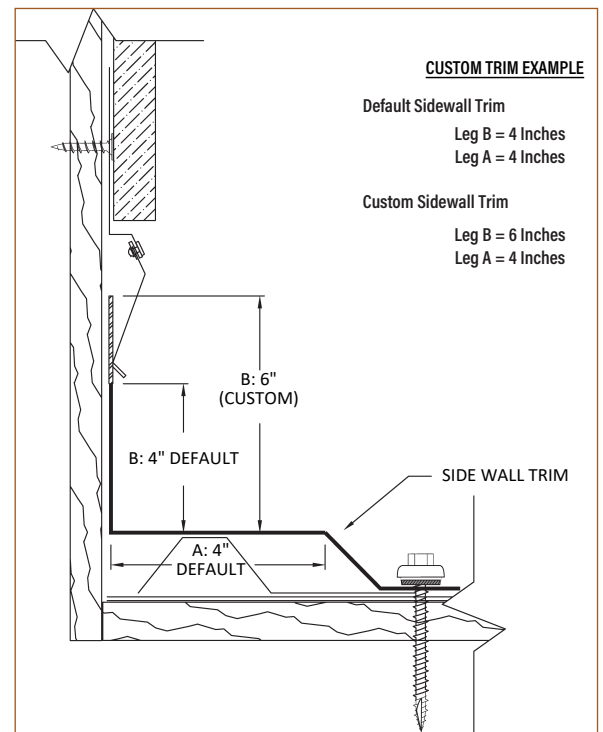

5V TRIM DIMENSIONS

DRIP
(5")

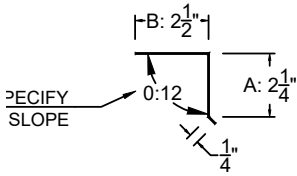

VALLEY
(18")

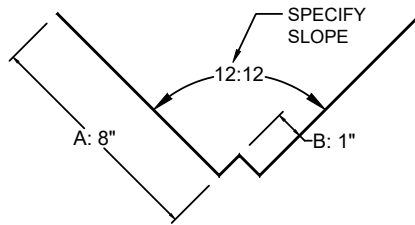

TRANSITION
(16")

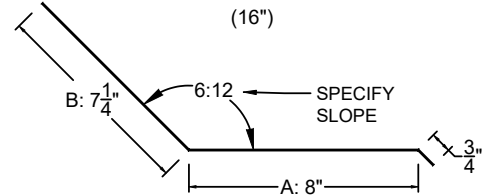

SIDEWALL
(10")

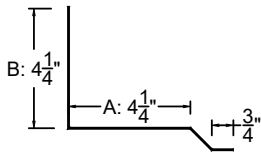

HEADWALL
(10")

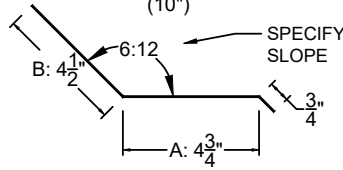

GABLE
(8.75")

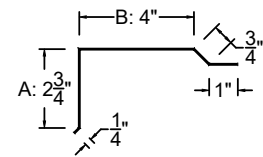

SWFL GABLE
(7.25")

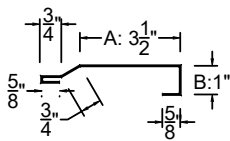

FLAT CAP
(14")

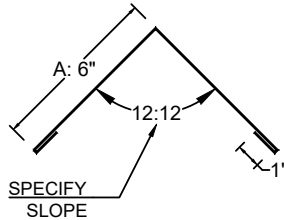

NOTCHABLE CAP
(13.5")

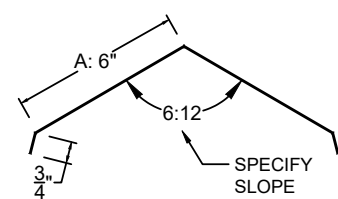

REGULAR STUCCO
(6")

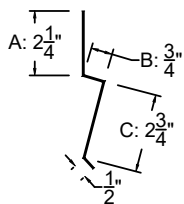

FIRST STUCCO
(6")

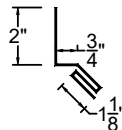

SECOND STUCCO
(4")

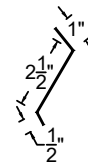

FOR CUSTOM TRIM INSTRUCTIONS, SEE PAGE 11 OF THIS GUIDE.

DETAILS AND DIMENSIONS SUBJECT TO CHANGE WITHOUT NOTICE. ALWAYS FOLLOW LOCAL BUILDING CODES.



AG TRIM DIMENSIONS

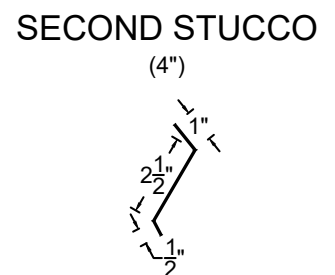
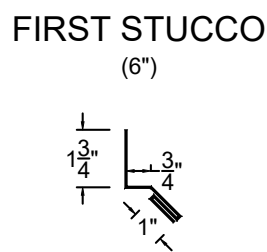
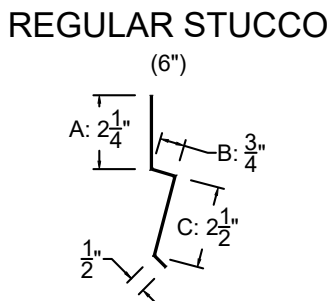
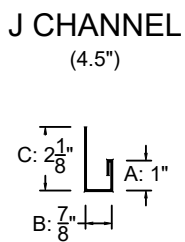
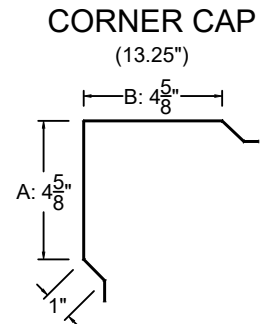
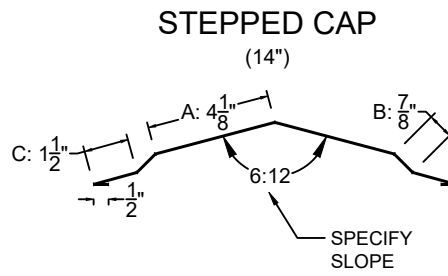
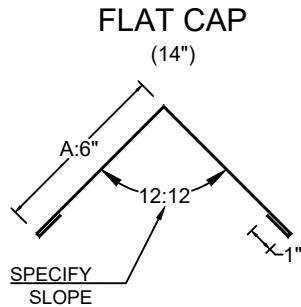
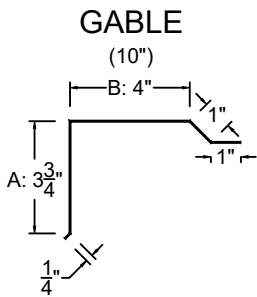
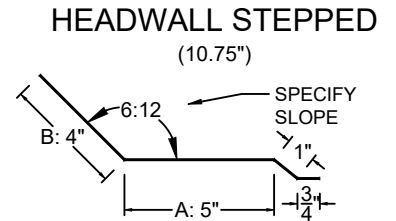
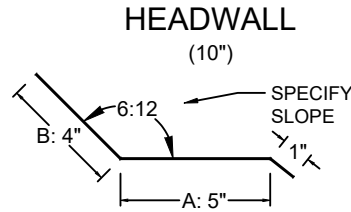
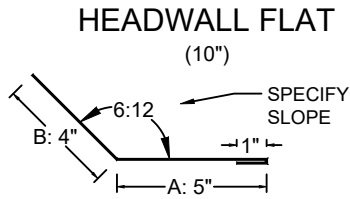
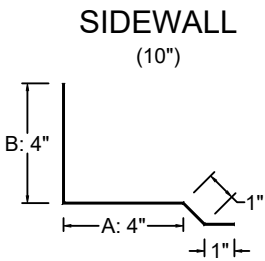
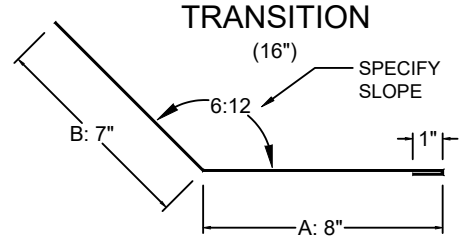
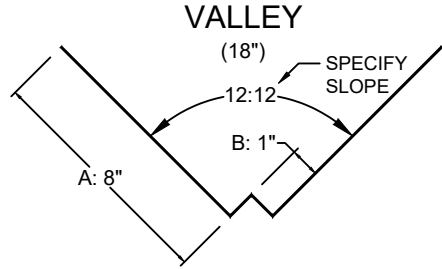
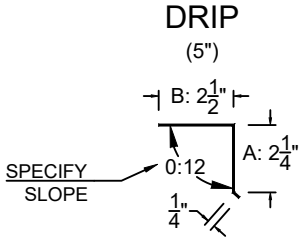

FOR CUSTOM TRIM INSTRUCTIONS, SEE PAGE 11 OF THIS GUIDE.
DETAILS AND DIMENSIONS SUBJECT TO CHANGE WITHOUT NOTICE. ALWAYS FOLLOW LOCAL BUILDING CODES.

PBR TRIM DIMENSIONS

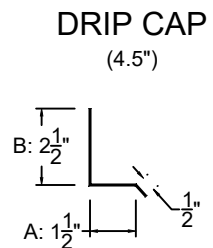
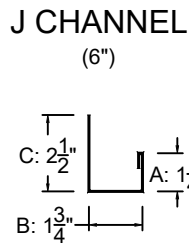
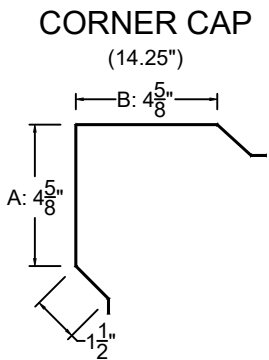
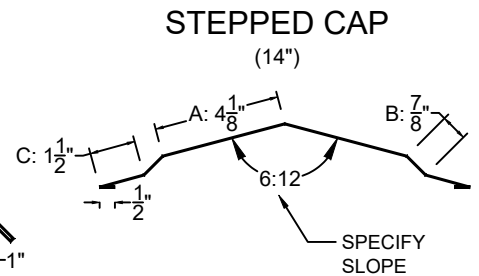
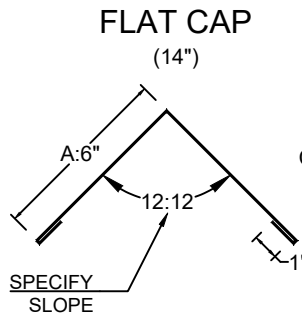
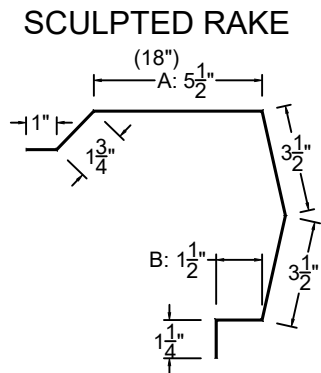
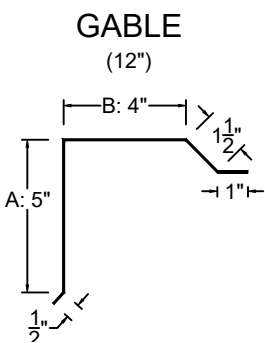
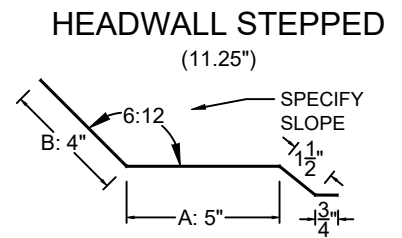
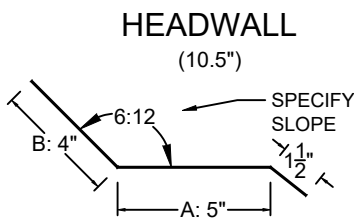
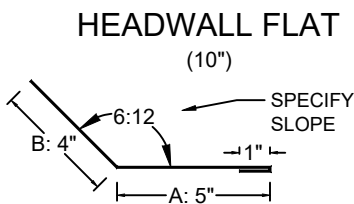
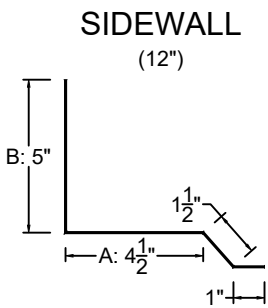
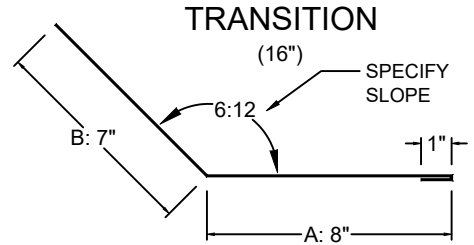
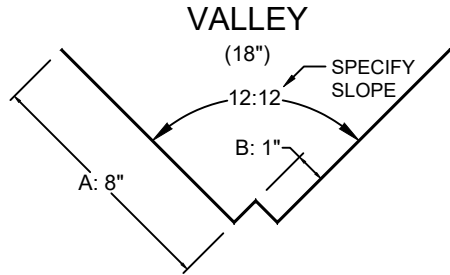
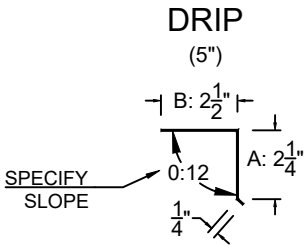

FOR CUSTOM TRIM INSTRUCTIONS, SEE PAGE 11 OF THIS GUIDE.
DETAILS AND DIMENSIONS SUBJECT TO CHANGE WITHOUT NOTICE. ALWAYS FOLLOW LOCAL BUILDING CODES.

EAVE CROSS SECTION

NOT TO SCALE

- 1** INSTALL EAVE DRIP BEFORE PANELS. ATTACH TO ROOF DECK WITH NAILS @ 4" OC MAX, OR USE PANCAKE/DECK SCREW TO MATCH PANEL FASTNER SPACING.
- 2** ADHERE (OPTIONAL) INSIDE CLOSURE TO PANEL RIBS.
- 3** INSTALL PANEL.

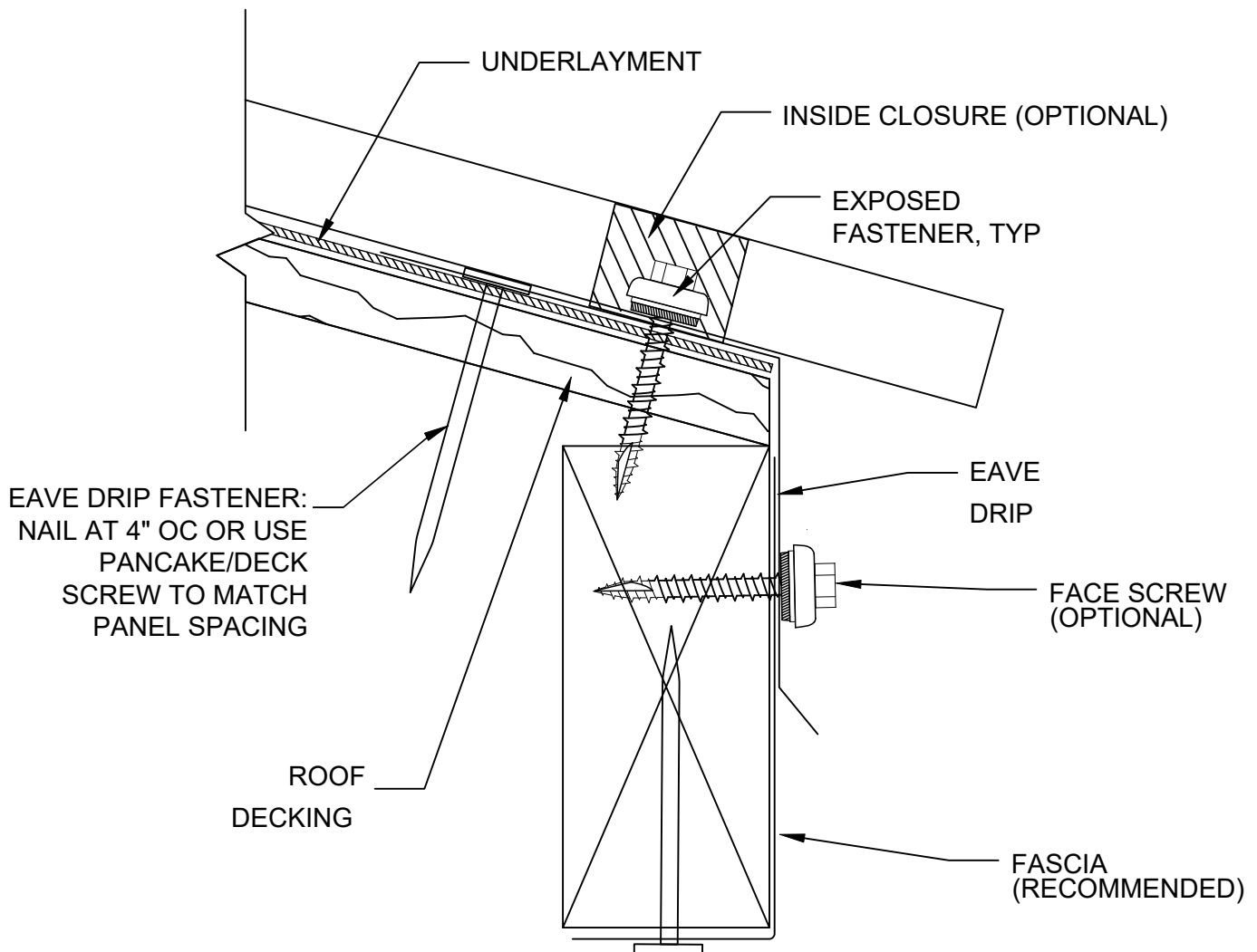

DETAILS AND DIMENSIONS SUBJECT TO CHANGE WITHOUT NOTICE. ALWAYS FOLLOW LOCAL BUILDING CODES.

RIDGE CROSS SECTION

NOT TO SCALE

- 1** INSTALL PANELS, LEAVING A GAP AT THE RIDGE FOR VENTILATION OR OTHER REQUIREMENTS. ATTACH TOP SCREW OF PANEL TO BE COVERED BY RIDGE CAP.
- 2** ADHERE (OPTIONAL) OUTSIDE CLOSURE TO PANELS. SOLID OR VENTED OPTIONS ARE AVAILABLE. CHECK RIDGE CAP SIZE TO ENSURE PROPER PLACEMENT OF CLOSURES.
- 3** INSTALL RIDGE CAP WITH FASTENERS. TO LIMIT DEFORMATION OF THE RIDGE CAP BETWEEN PANEL RIBS, FASTEN THE RIDGE CAP BY DRIVING SCREWS THROUGH THE RIDGE CAP AND INTO THE PANEL RIB.

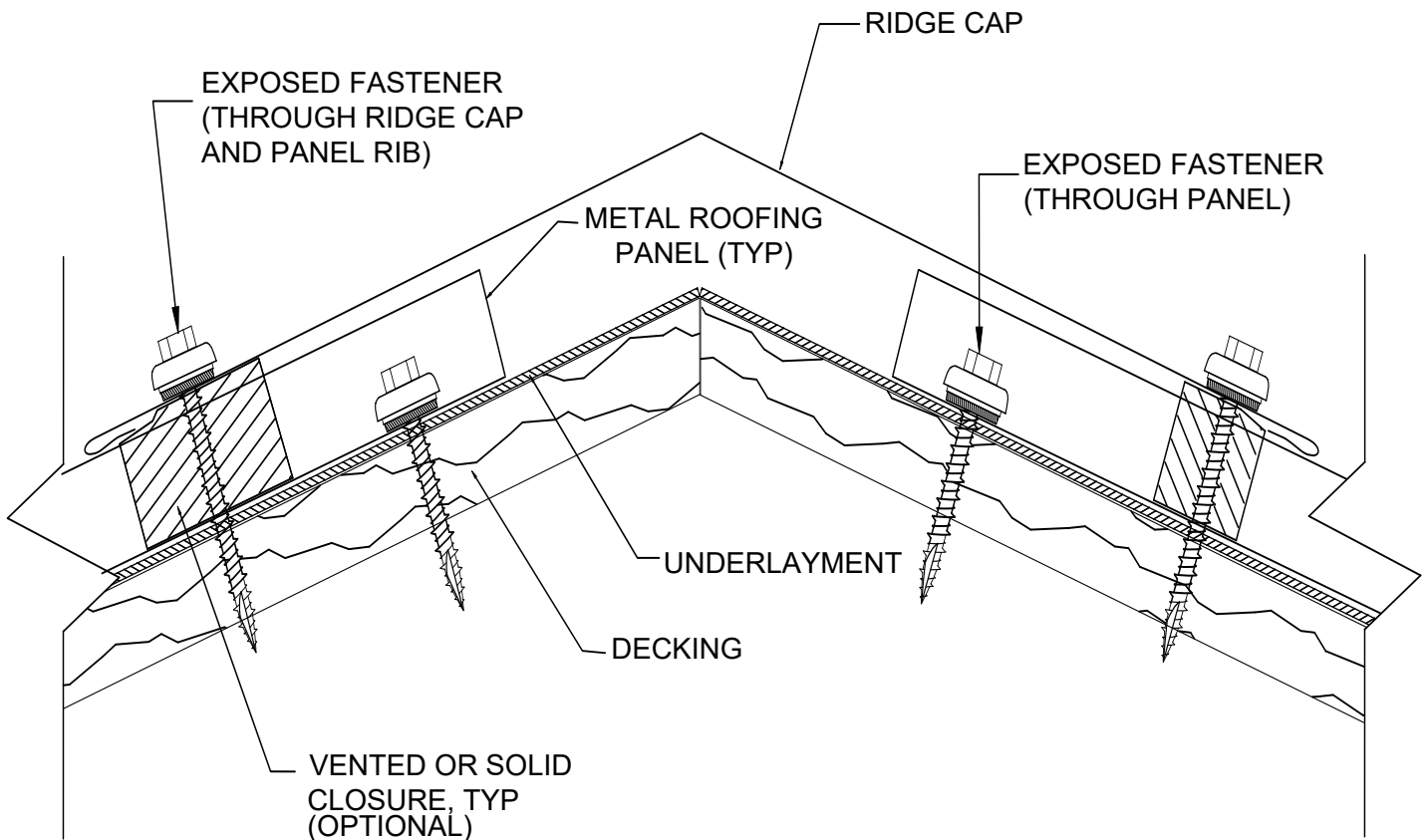

DETAILS AND DIMENSIONS SUBJECT TO CHANGE WITHOUT NOTICE. ALWAYS FOLLOW LOCAL BUILDING CODES.

HIGH SIDE RIDGE CROSS SECTION

NOT TO SCALE

- 1 INSTALL PANELS.
- 2 ADHERE (OPTIONAL) CLOSURE TO THE PANEL.
- 3 INSTALL HIGH SIDE CAP AND FASTEN TO ROOF DECK AND FASCIA BOARD.

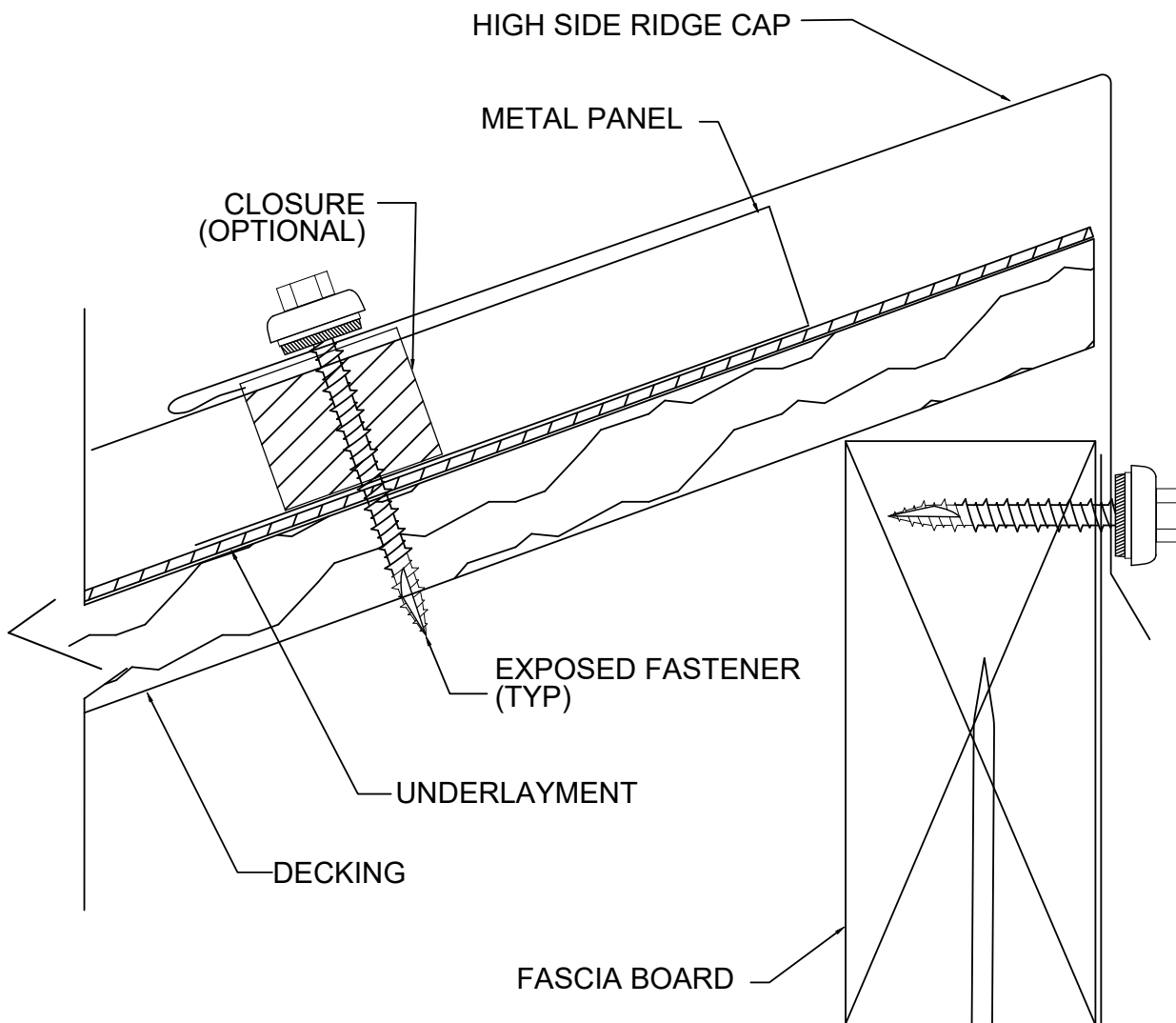

DETAILS AND DIMENSIONS SUBJECT TO CHANGE WITHOUT NOTICE. ALWAYS FOLLOW LOCAL BUILDING CODES.

GABLE CROSS SECTION

NOT TO SCALE

- 1** RUN PANELS ACROSS ROOF AND TRIM LAST PANEL AS REQUIRED TO FIT.
- 2** ADHERE BUTYL TAPE OR OTHER SEALANT TO DECK SIDE OF GABLE TRIM (OPTIONAL).
- 3** INSTALL GABLE TRIM BY FASTENING THROUGH THE DECK FASCIA.

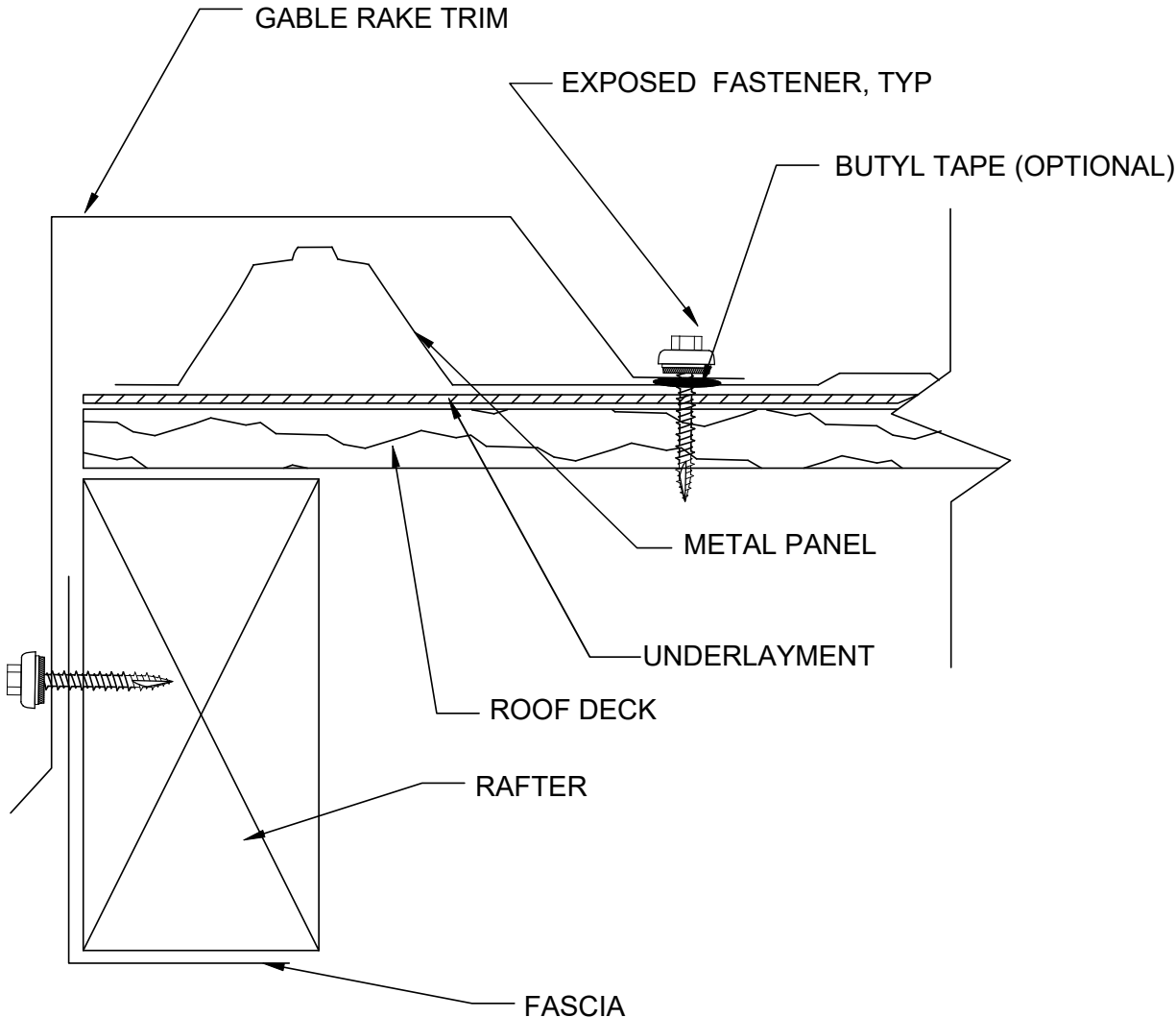

DETAILS AND DIMENSIONS SUBJECT TO CHANGE WITHOUT NOTICE. ALWAYS FOLLOW LOCAL BUILDING CODES.

VALLEY CROSS SECTION

NOT TO SCALE

- 1** INSTALL UNDERLAYMENT CONTINUOUS THROUGH VALLEY.
- 2** LAY VALLEY TRIM AND FASTEN 2" FROM OUTSIDE EDGE AND 12" O.C. MAX.
- 3** APPLY SECOND LAYER OF UNDERLAYMENT OVER OUTER EDGE OF VALLEY, APPROX 3" DOWN ONTO VALLEY ON BOTH SIDES (COVER VALLEY FASTENERS).
- 4** ADHERE (OPTIONAL) EXPANDING FOAM.
- 5** INSTALL METAL ROOF PANELS.

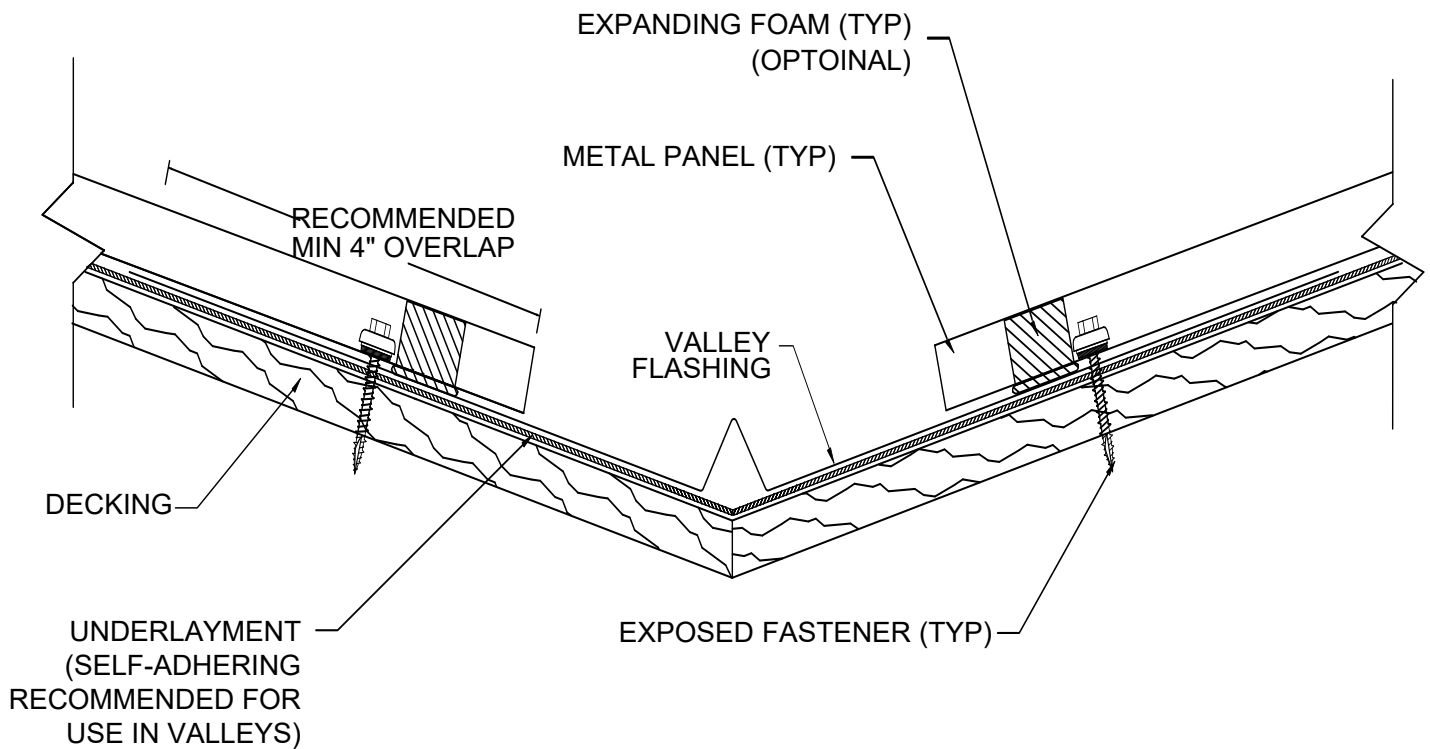

DETAILS AND DIMENSIONS SUBJECT TO CHANGE WITHOUT NOTICE. ALWAYS FOLLOW LOCAL BUILDING CODES.

TRANSITION CROSS SECTION

NOT TO SCALE

- 1** INSTALL LOWER PANELS.
- 2** ADHERE (OPTIONAL) OUTSIDE CLOSURE.
- 3** INSTALL TRANSITION TRIM BY FASTENING THROUGH TRIM AND LOWER PANEL. FASTEN UPPER EDGE WITH DECK SCREWS OR PANCAKE SCREWS.
- 4** ADHERE (OPTIONAL) INSIDE CLOSURE AND INSTALL UPPER PANEL. FASTEN THROUGH PANEL AND FLASHING.

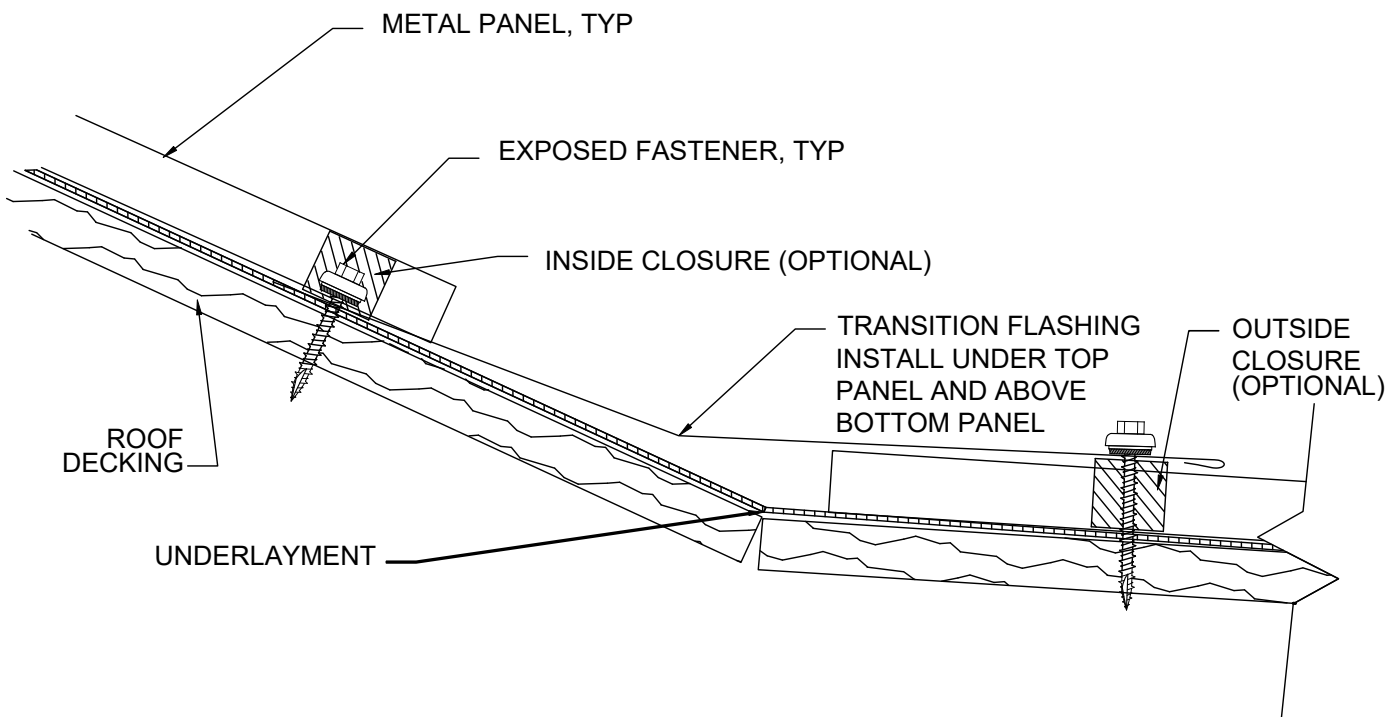

DETAILS AND DIMENSIONS SUBJECT TO CHANGE WITHOUT NOTICE. ALWAYS FOLLOW LOCAL BUILDING CODES.

SIDEWALL CROSS SECTION

NOT TO SCALE

- 1 RUN PANELS ACROSS ROOF DECK, CUTTING AND BENDING LAST PANEL TO FIT.
- 2 INSTALL LAST ROOF PANEL.
- 3 PLACE ENDWALL AND FASTEN EVERY 24" O.C. MAX.
- 4 FASTEN UPPER EDGE OF STUCCO STOP EVERY 24" O.C. MAX.

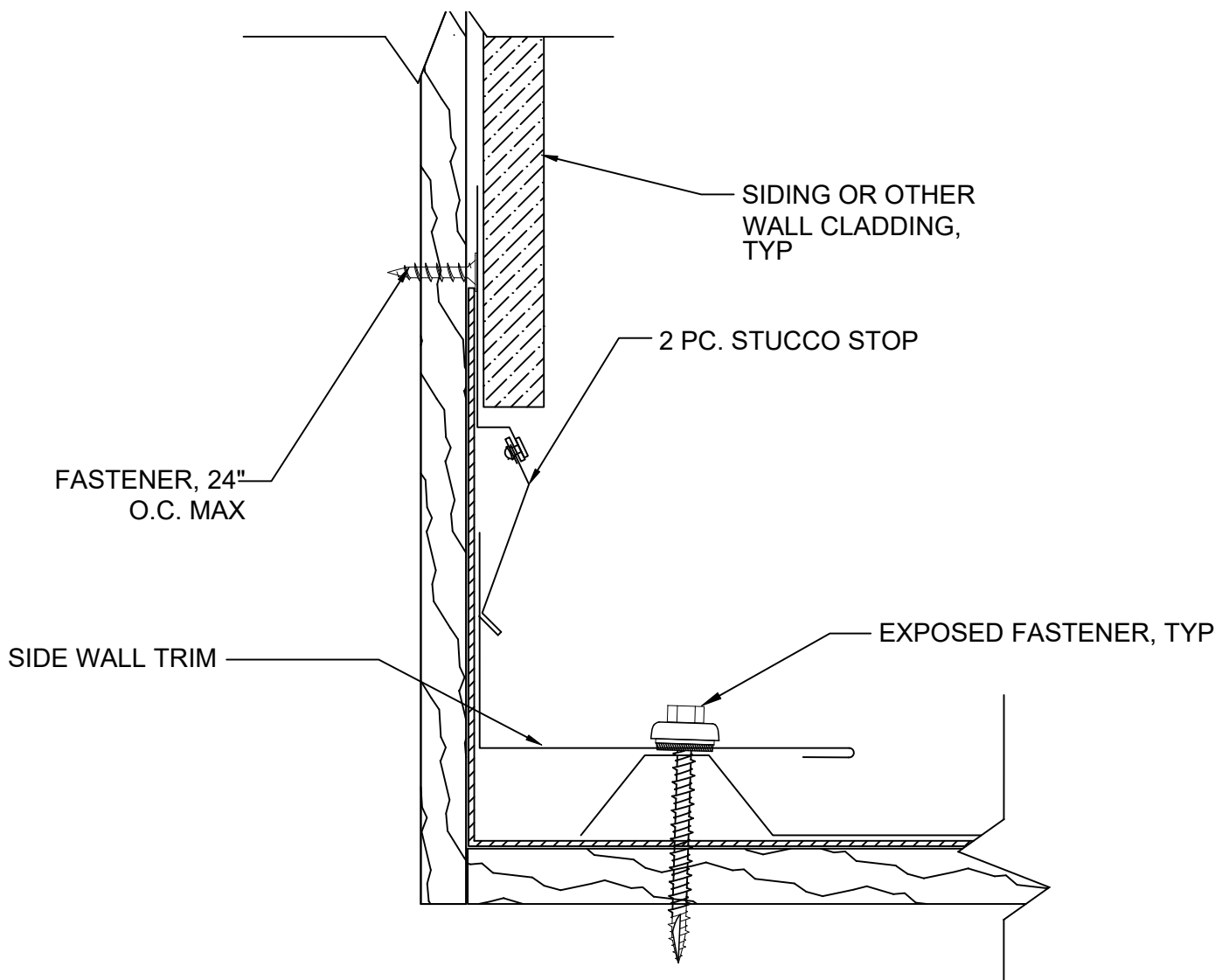

DETAILS AND DIMENSIONS SUBJECT TO CHANGE WITHOUT NOTICE. ALWAYS FOLLOW LOCAL BUILDING CODES.

ENDWALL CROSS SECTION

NOT TO SCALE

- 1** INSTALL ROOF PANELS.
- 2** PLACE ENDWALL AND FASTEN EVERY 24" O.C. MAX.
- 3** FASTEN UPPER EDGE OF STUCCO STOP EVERY 24" O.C. MAX.

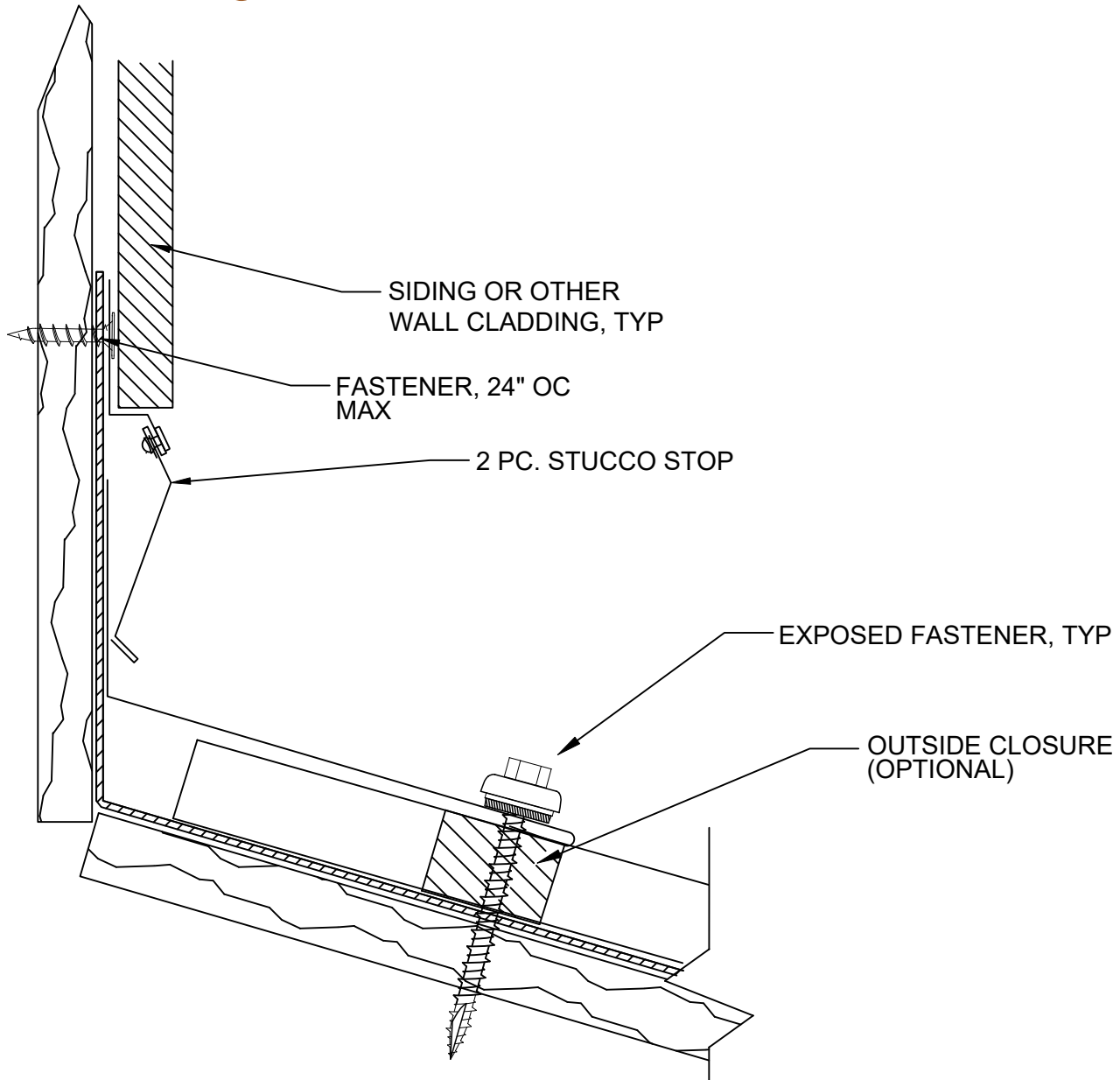

DETAILS AND DIMENSIONS SUBJECT TO CHANGE WITHOUT NOTICE. ALWAYS FOLLOW LOCAL BUILDING CODES.

NOTES





INTEGRITY METALS

Architectural Fabrication

6040 Old Dixie Highway • Vero Beach, FL 32967

 772-584-2654  [INTEGRITYMETALSFL.COM](https://www.integritymetalsfl.com)